

DATA IMAGE CORPORATION

LCD Module Specification

ITEM NO.: GM24644SR-01

Table of Contents

1. COVER & CONTENTS	1
2. RECORD OF REVISION	2
3. GENERAL SPECIFICATIONS	3
4. ABSOLUTE MAXIMUM RATINGS	4
5. ELECTRICAL CHARACTERISTICS	5
6. ELECTRO-OPTICAL CHARACTERISTIC	5
7. TIMING CHARACTERISTICS	7
8. PIN CONNECTIONS	8
9. POWER SUPPLY	8
10. BLOCK DIAGRAM	9
11. QUALITY ASSURANCE	15
12. LOT NUMBERING SYSTEM	19
13. LCM NUMBERING SYSTEM	19
14. PRECAUTIONS IN USE LCM	20
15. OUTLINE DRAWING	21

Approved by	Checked by QC. Div	Checked by Pro. Div	Checked by R&D. Div.	Drawn by
	Final Revision: C	Sheet Code:	Issued Date: 2000/1/26	Total Page: 21

2. RECORD OF REVISION

Rev	Date	Item	Page	Comment
B	JAN/11/00	10	9	Change PCB REV:B for Add RT1 3.3K Thermistor.
C	JAN/26/00	11.2.2	16	Change "Definition of applicable Zones", A=Display Area and, B=Non-Display area
		11.2.3	17	Change the measurement of "Inspection Parameters" 1. Black or white spots 2. Scratch, Substances 3. Air Bubbles (Between glass and polarizer)

3. GENERAL SPECIFICATION

Display Format : 240 (W) × 64 (H) dots

Dots Size : 0.41 (W) × 0.41 (H) mm

View Area : 112 (W) × 32 (H) mm

General Dimensions : 149 (W) × 56 (H) × 9.5 (T) mm Max.

Weight : 90 g max.

LCD Type : STN Gray STN Yellow FSTN

Polarizer mode : Reflective Transflective

Transmissive Negative

View Angle : 6 O'clock 12 O'clock Others _____

Backlight : LED EL CCFL

Backlight Color : Yellow green Amber Blue Green

White Others

Controller / Driver : T6963C

Temperature Range : Normal Wide Temperature

Operating	0 to 50°C	Operating	-20 to 70°C
Storage	-10 to 60°C	Storage	-30 to 80°C

4. ABSOLUTE MAXIMUM RATINGS

4.1 ELECTRICAL ABSOLUTE MAXIMUM RATINGS

V_{SS}= 0V, Ta = 25°C

Item	Symbol	Min.	Max.	Unit
Supply Voltage (Logic)	V _{DD} -V _{SS}	0	7	V
Supply Voltage (LCD Driver)	V _{DD} -V _{EE}	0	25	V
Input Voltage	V _I	V _{SS}	V _{DD}	V
Operating Temperature	T _{OP}	0	50	°C
Storage Temperature	T _{STG}	-10	60	°C

4.2 ENVIRONMENTAL ABSOLUTE MAXIMUM RATINGS

Item	Operating		Storage		Comment
	(Min.)	(Max.)	(Min.)	(Max.)	
Ambient Temp	0	50	-10	60	Note (1)
Humidity	Note (2)		Note(2)		Without Condensation
Vibration	--	4.9M/S ²	--	19.6M/S ²	XYZ Direction
Shock	--	29.4M/S ²	--	490M/S ²	XYZ Direction

Note(1) Ta = 0°C : 50Hr Max.

Note(2) Ta ≤ 40°C : 90% RH Max.

Ta ≥ 40°C : Absolute humidity must be lower than the humidity of 90% RH at 40°C.

5. ELECTRICAL CHARACTERISTICS

Item	Symbol	Condition	Min.	Typ.	Max.	Unit
Supply Voltage (Logic)	V _{DD-VSS}		4.5	5.0	5.5	V
Supply Voltage (LCD)	V _{DD-V0}	0°C	12.5	13	13.5	V
		25°C	11.3	12.0	12.6	
		50°C	10.5	11.0	11.5	
Input Voltage	V _{IH}	--	V _{SS-2.2}	--	V _{DD}	V
	V _{IL}		0	--	0.8	
Logic Supply Current	I _{DD}	V _{DD-VSS} =5V	--	9.8	--	mA
	I _{EE}		--	0.06	--	mA

6. ELECTRO-OPTICAL CHARACTERISTICS

ITEM	Symbol	Condition	Min.	Typ.	Max.	Unit	Ref.
Rise Time	Tr	0°C	470	650	800	ms	Note (1)
		25°C	187	198	206		
Fall Time	Tf	0°C	450	500	750	ms	
		25°C	142	146	154		
Contrast	CR	25°C	--	2.5	--		Note (3)
View Angle	θ ₁ ~θ ₂ ∅ ₁ , ∅ ₂	25°C & CR≥3	--	30	--		Note (2)
			--	30	--		
Frame Frequency	Ff	25°C	--	70	--	Hz	

Note (1) & (2) : See next page

Note (3) : Contrast ratio is defined under the following condition:

$$CR = \frac{\text{Brightness of non-selected condition}}{\text{Brightness of selected condition}}$$

- (a). Temperature ----- 25°C
- (b). Frame frequency ---- 70Hz
- (c). Viewing angle ----- θ= 0°, ∅ = 0°
- (d). Operating voltage --- 12.0V

Note (1) Response time is measured as the shortest period of time possible between the change in state of an LCD segment as demonstrated below:

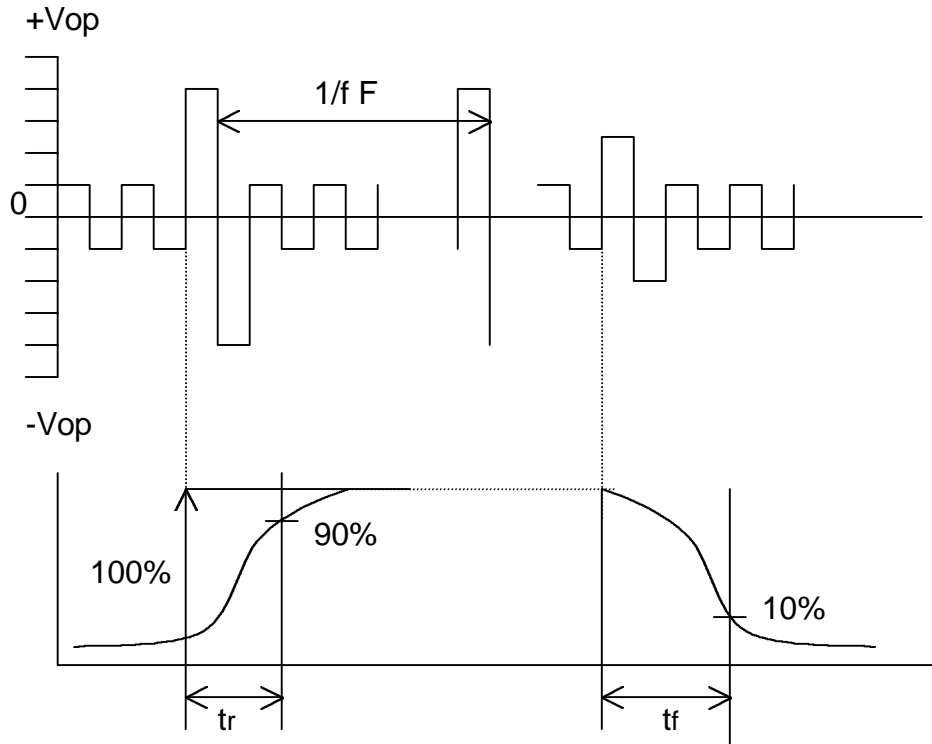

Condition:

- (a) . Temperature ----- $25^{\circ}C$
- (b) . Frame frequency ----- 70Hz
- (c) . View Angle ----- $\theta = 0^{\circ}, \varnothing=0^{\circ}$
- (d) . Operating voltage ----- 12.0V

Note (2) Definition of View Angle

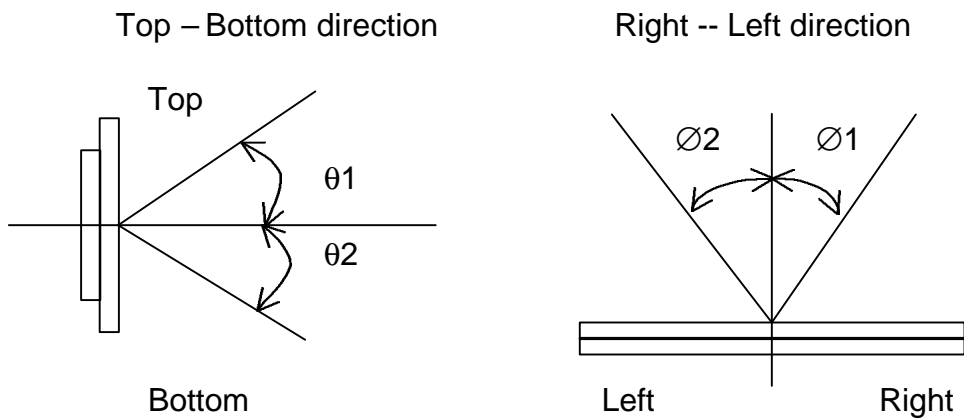

7. TIMING CHARACTERISTICS

£ Switching Characteristics (2) Bus Timing

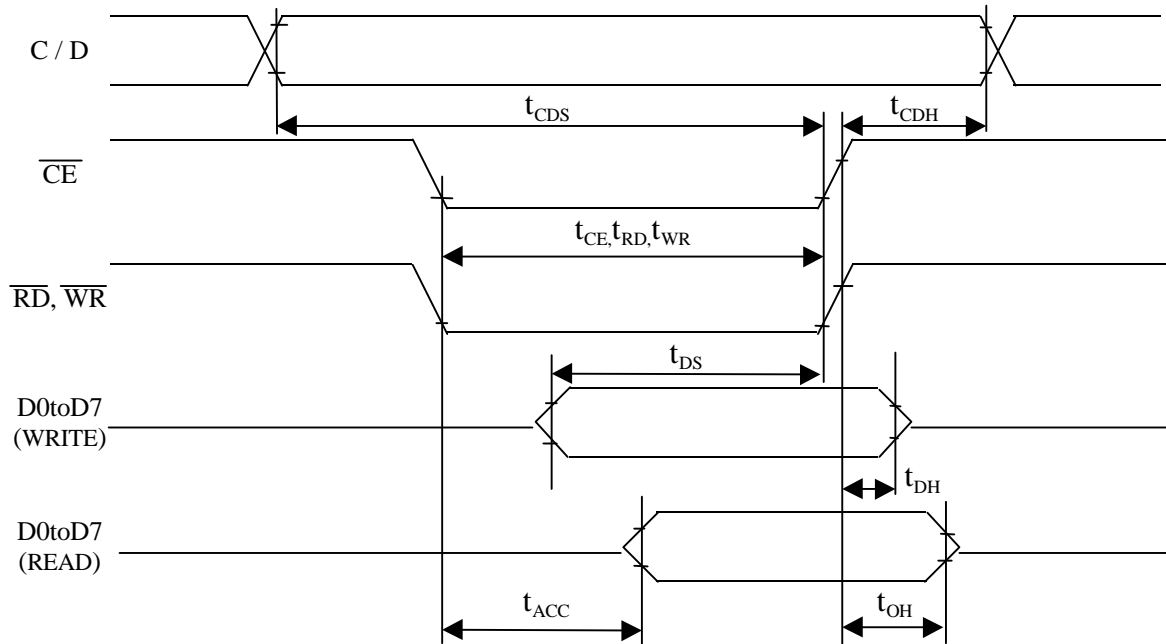

TEST CONDITIONS (Unless otherwise noted. $V_{DD} = 5.0V \pm 10\%$, $V_{SS} = 0V$, $T_a = -20$ to $75^\circ C$)

ITEM	SYMBOL	TEST CONDITIONS	MIN	MAX	UNIT
C / D Set-up Time	t_{CDS}	--	100	--	ns
C / D Hold Time	t_{CDH}	--	10	--	ns
\overline{CE} , \overline{RD} , \overline{WR} Pulse Width	t_{CE}, t_{RD}, t_{WR}	--	80	--	ns
Data Set-up Time	t_{DS}	--	80	--	ns
Data Hold Time	t_{DH}	--	40	--	ns
Access Time	t_{ACC}	--	--	150	ns
Output Hold Time	t_{OH}	--	10	50	ns

8. PIN CONNECTIONS

Pin	Symbol	Function
1	V _{SS}	Ground (0 V)
2	FGND	Frame Ground (Connect to Bezel)
3	NC	No Connection
4	V _{DD}	Power Supply (+5V)
5	/RD	Data Read
6	/WR	Data Write
7	C/D	Command / Data
8	/CE	Chip Enable
9	/RESET	IC Reset
10	PWM	Pulse Width Modulation for LCD Contrast Control.
11	DB1	Data Bus Line
12	DB0	
13	DB3	
14	DB2	
15	DB5	
16	DB4	
17	DB7	
18	DB6	
19	NC	No Connection
20	FS	Font size Select, L = 8 × 8, H = 8 × 6

9. POWER SUPPLY

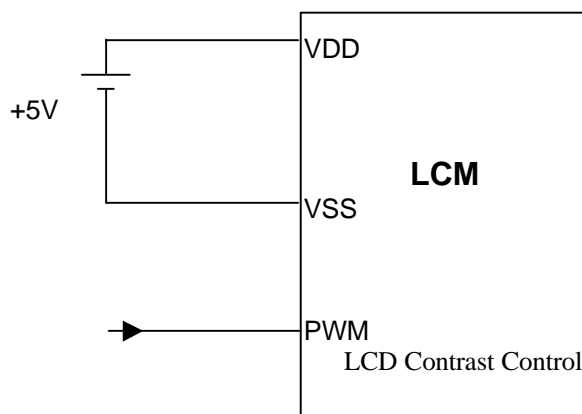

10. BLOCK DIAGRAM

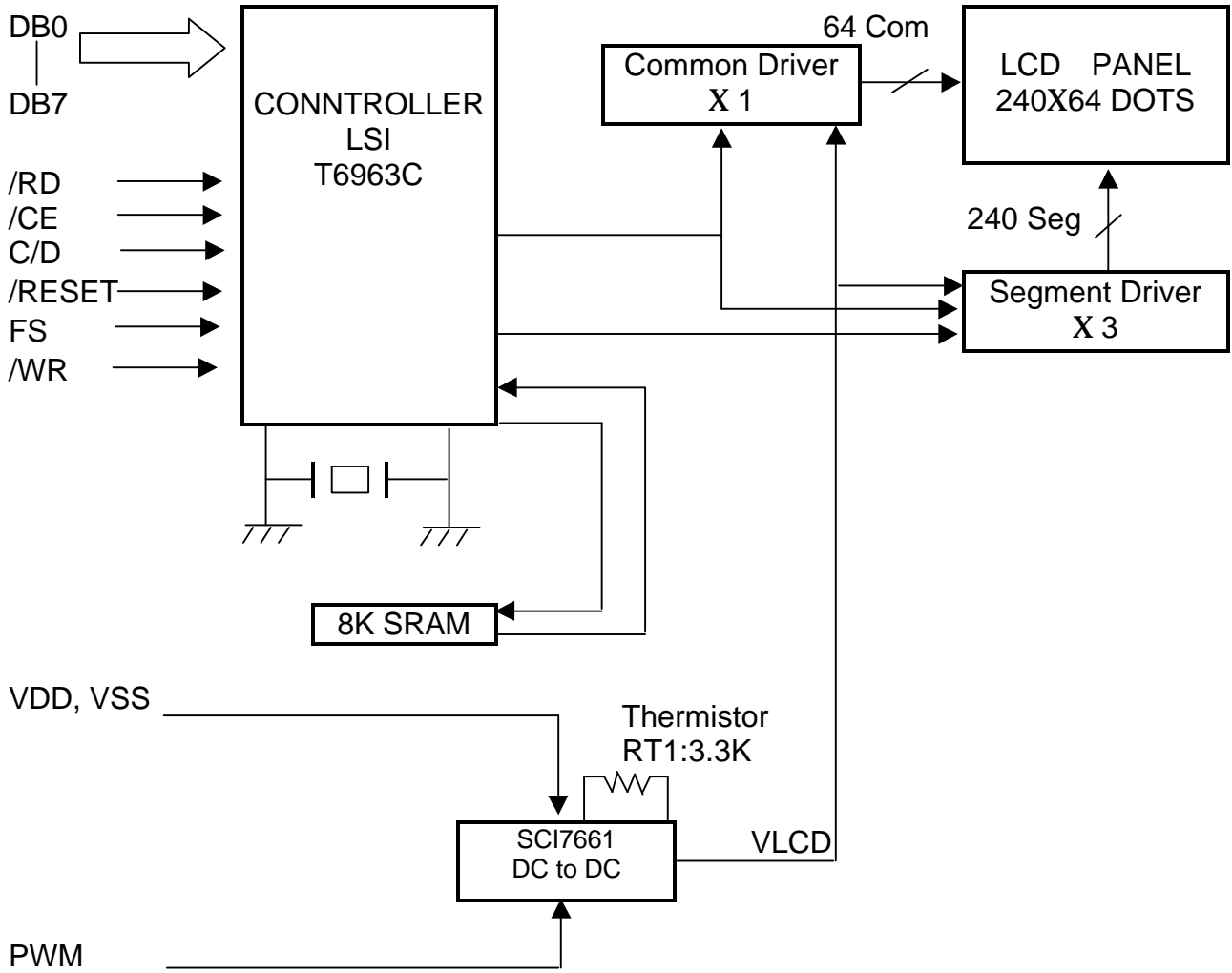

• Flowchart of communications with MPU

(1) Status Read

A status check must be performed before data is read or written.

Status check

The Status of T6963C can be read from the data lines.

\overline{RD}	L
\overline{WR}	H
\overline{CE}	L
C / D	H
D0 to D7	Status word

The T6963C status word format is as follows:

MSB							LSB
STA7 D7	STA6 D6	STA5 D5	STA4 D4	STA3 D3	STA2 D2	STA1 D1	STA0 D0

STA0	Check command execution capability	0 : Disable 1 : Enable
STA1	Check data read / write capability	0 : Disable 1 : Enable
STA2	Check Auto mode data read capability	0 : Disable 1 : Enable
STA3	Check Auto mode data write capability	0 : Disable 1 : Enable
STA4	Not used	
STA5	Check controller operation capability	0 : Disable 1 : Enable
STA6	Error flag. Used for Screen Peek and Screen copy commands.	0 : No error 1 : Error
STA7	Check the blink condition	0 : Display off 1 : Normal display

- (Note 1) It is necessary to check STA0 and STA1 at the same time.
There is a possibility of erroneous operation due to a hardware interrupt.
- (Note 2) For most modes STA0 / STA1 are used as a status check.
- (Note 3) STA2 and STA3 are valid in Auto mode; STA0 and STA1 are invalid.

Status checking flow

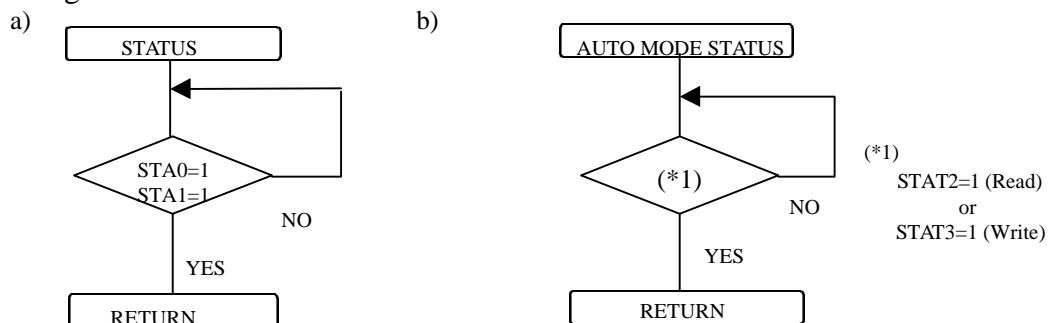

- (Note 4) When using the MSB = 0 command, a Status Read must be performed.
If a status check is not carried out, the T6963C cannot operate normally, even after a delay time.
The hardware interrupt occurs during the address calculation period (at the end of each line).
If a MSB = 0 command is sent to the T6963C during this period, the T6963C enters Wait status.
If a status check is not carried out in this state before the next command is sent, there is the Possibility that the command or data will not be received.

(2) Setting data

When using the T6963C, first set the data, then set the command.

Procedure for sending a command

a) The case of 1 data

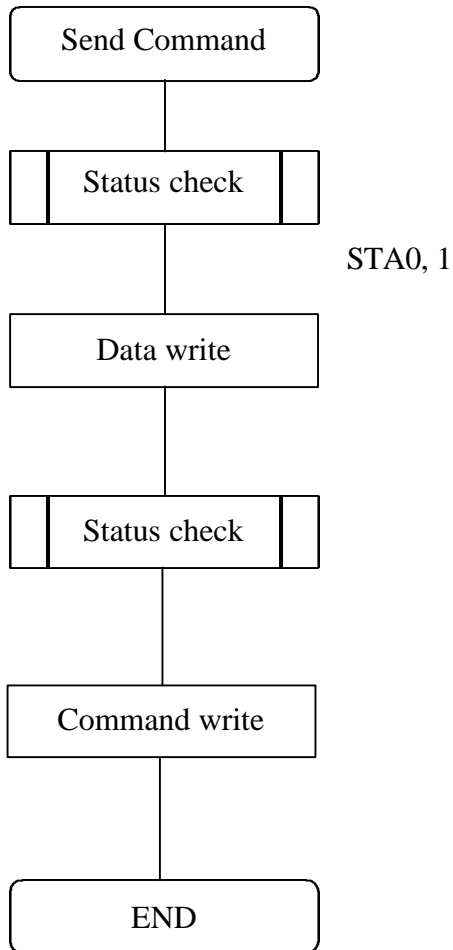

b) The case of 2 data

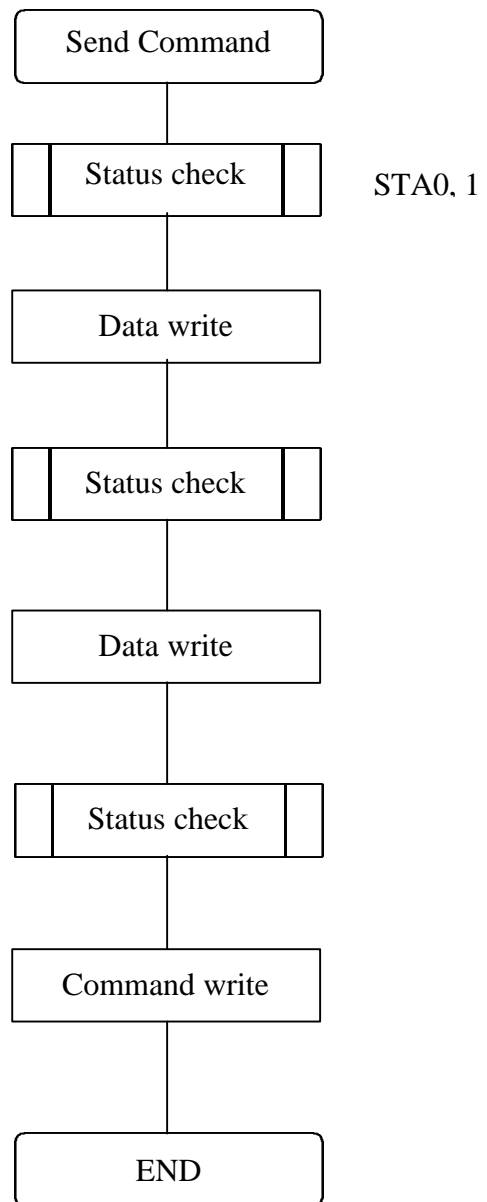

(Note) When sending more than two data, the last datum (or last two data) is valid.

COMMAND DEFINITIONS

COMMAND	CODE	D1	D2	FUNCTION
REGISTERS SETTING	00100001	X address	Y address	Set Cursor Pointer
	00100010	Data	00H	Set Offset Register
	00100100	Low address	High address	Set Address Pointer
SET CONTROL WORD	01000000	Low address	High address	Set Text Home Address
	01000001	Columns	00H	Set Text Area
	01000010	Low address	High address	Set Graphic Home Address
	01000011	Columns	00H	Set Graphic Area
MODE SET	1000X000	i X	i X	OR mode
	1000X001	i X	i X	EXOR mode
	1000X011	i X	i X	AND mode
	1000X100	i X	i X	Text Attribute mode
	10000XXX	i X	i X	Internal CG ROM mode
	10001XXX	i X	i X	External CG RAM mode
DISPLAY MODE	10010000	i X	i X	Display off
	1001XX10	i X	i X	Cursor on, blink off
	1001 XX11	i X	i X	Cursor on, blink on
	100101 XX	i X	i X	Text on, graphic off
	100110 XX	i X	i X	Text off, graphic on
	100111 XX	i X	i X	Text on, graphic on
CURSOR PATTERN SELECT	10100000	i X	i X	1-line cursor
	10100001	i X	i X	2-line cursor
	10100010	i X	i X	3-line cursor
	10100011	i X	i X	4-line cursor
	10100100	i X	i X	5-line cursor
	10100101	i X	i X	6-line cursor
	10100110	i X	i X	7-line cursor
	10100111	i X	i X	8-line cursor
DATA AUTO READ / WRITE	10110000	i X	i X	Set Data Auto Write
	10110001	i X	i X	Set Data Auto Read
	10110010	i X	i X	Auto Reset
DATA READ / WRITE	11000000	Data	i X	Data Write and Increment ADP
	11000001	i X	i X	Data Read and Increment ADP
	11000010	Data	i X	Data Write and Decrement ADP
	11000011	i X	i X	Data Read and Decrement ADP
	11000100	Data	i X	Data Write and Nonvariable ADP
	11000101	i X	i X	Data Read and Nonvariable ADP
SCREEN PEEK	11100000	i X	i X	Screen Peek
SCREEN COPY	11101000			Screen Copy
BIT SET / RESET	11110XXX	i X	i X	Bit Reset
	11111XXX	i X	i X	Bit Set
	1111X000	i X	i X	Bit 0 (LSB)
	1111X001	i X	i X	Bit 1
	1111X010	i X	i X	Bit 2
	1111X011	i X	i X	Bit 3
	1111X100	i X	i X	Bit 4
	1111X101	i X	i X	Bit 5
	1111X110	i X	i X	Bit 6
	1111X111	i X	i X	Bit 7 (MSB)

X : invalid

£ Setting registers

CODE	HEX.	FUNCTION	D1	D2
00100001	21H	SET CURSOR POINTER	X ADRS	Y ADRS
00100010	22H	SET OFFSET REGISTER	DATA	00H
00100100	24H	SET ADDRESS POINTER	LOW ADRS	HIGH ADRS

(1) Set Cursor Pointer

The position of the cursor is specified by X ADRS and Y ADRS. The cursor position can only be moved by this command. Data read / write from the MPU never changes the cursor pointer. X ADRS and Y ADRS are specified as follows.

X ADRS 00H to 4FH (lower 7 bits are valid)

Y ADRS 00H to 1FH (lower 5 bits are valid)

a) Single – Scan

X ADRS 00 to 4FH



b) Dual – Scan

X ADRS 00 to 4FH

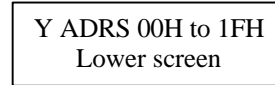
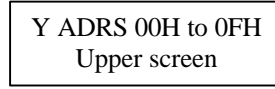

(2) Set Offset Register

The offset register is used to determine the external character generator RAM area. The T6963C has a 16-bit address bus as follows:

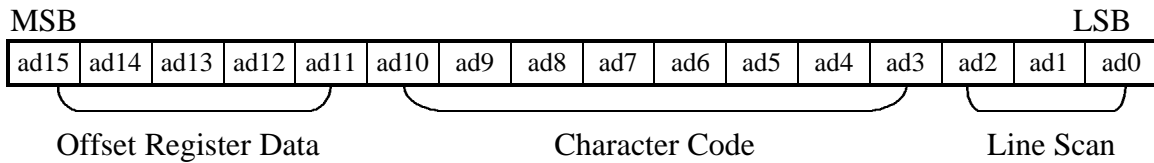

CHARACTER CODE MAP
ROM code 0101

CHARACTER CODE MAP
ROM code 0101

MSB \ LSB	0	1	2	3	4	5	6	7	8	9	A	B	C	D	E	F
0		!	"	#	\$	%	&	'	()	*	+	,	-	.	/
1	0	1	2	3	4	5	6	7	8	9	:	;	<	=	>	?
2	@	A	B	C	D	E	F	G	H	I	J	K	L	M	N	O
3	P	Q	R	S	T	U	V	W	X	Y	Z	[\]	^	_
4	`	a	b	c	d	e	f	g	h	i	j	k	l	m	n	o
5	P	q	r	s	t	u	v	w	x	y	z	{		}	~	
6	5	ü	ë	ä	å	ä	å	ä	å	ä	å	ä	å	ä	å	ä
7	é	æ	ë	ö	ö	ö	ö	ö	ö	ö	ö	ö	ö	ö	ö	ö

11. QUALITY ASSURANCE

11.1 Test Condition

11.1.1 Temperature and Humidity(Ambient Temperature)

Temperature : $20 \pm 5^{\circ}\text{C}$

Humidity : $65 \pm 5\%$

11.1.2 Operation

Unless specified otherwise, test will be conducted with LCM in operation.

11.1.3 Container

Unless specified otherwise, vibration test will be conducted on module only.

11.1.4 Test Frequency

Single cycle.

11.1.5 Test Method

No.	Parameter	Conditions	Regulations
1	High Temperature Operating	$50 \pm 2^{\circ}\text{C}$	Note 3
2	Low Temperature Operating	$0 \pm 2^{\circ}\text{C}$	Note 3
3	High Temperature Storage	$60 \pm 2^{\circ}\text{C}$	Note 3
4	Low Temperature Storage	$-10 \pm 2^{\circ}\text{C}$	Note 3
5	Vibration Test (Non-operation state)	Total fixed amplitude : 1.5mm Vibration Frequency : 10 ~ 55Hz One cycle 60 seconds to 3 directions of X.Y.Z. for each 15 minutes	Note 3
6	Damp Proof Test (Non-operation state)	$40^{\circ}\text{C} \pm 2^{\circ}\text{C}$, 90~95%RH, 96h	Note 1,2
7	Shock Test (Non-operation state)	To be measured after dropping from 60cm high once concrete surface in packing state	Note 3

Note 1: Returned under normal temperature and humidity for 4 hrs.

Note 2: No dew condensation to be observed.

Note 3: No change on display and in operation under the test condition

11.2 Inspection condition

11.2.1 Inspection conditions

The LCD shall be inspected under 40W white fluorescent light.

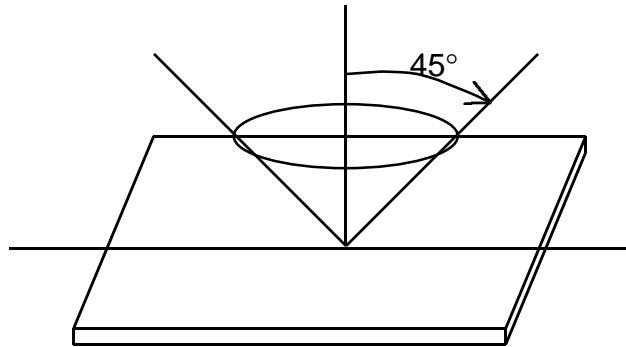

11.2.2 Definition of applicable Zones

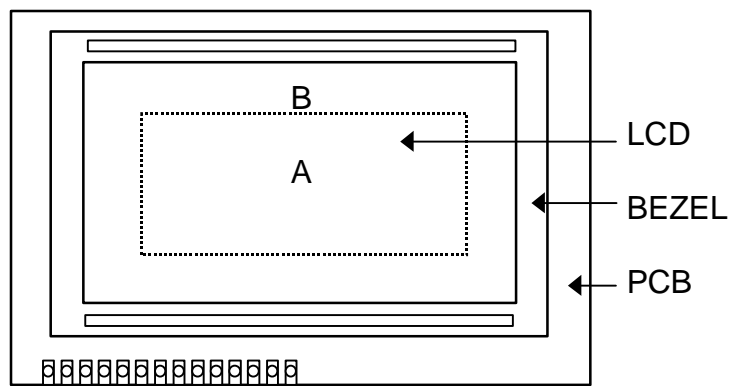

A : Display Area
B : Non-Display Area

11.2.3 Inspection Parameters

No.	Parameter	Criteria																										
1	Black or White spots	<table border="1"> <thead> <tr> <th rowspan="2">Zone Dimension</th> <th colspan="2">Acceptable number</th> <th rowspan="2">Class Of Defects</th> <th rowspan="2">AQL Level</th> </tr> <tr> <th>A</th> <th>B</th> </tr> </thead> <tbody> <tr> <td>D < 0.15</td> <td>*</td> <td>*</td> <td rowspan="4">Minor</td> <td rowspan="4">2.5</td> </tr> <tr> <td>0.15 ≤ D ≤ 0.2</td> <td>4</td> <td>4</td> </tr> <tr> <td>0.2 ≤ D ≤ 0.25</td> <td>2</td> <td>2</td> </tr> <tr> <td>D ≤ 0.3</td> <td>0</td> <td>1</td> </tr> </tbody> </table> <p>D = (Long + Short) / 2 * : Disregard</p>	Zone Dimension	Acceptable number		Class Of Defects	AQL Level	A	B	D < 0.15	*	*	Minor	2.5	0.15 ≤ D ≤ 0.2	4	4	0.2 ≤ D ≤ 0.25	2	2	D ≤ 0.3	0	1					
Zone Dimension	Acceptable number			Class Of Defects	AQL Level																							
	A	B																										
D < 0.15	*	*	Minor	2.5																								
0.15 ≤ D ≤ 0.2	4	4																										
0.2 ≤ D ≤ 0.25	2	2																										
D ≤ 0.3	0	1																										
2	Scratch, Substances	<table border="1"> <thead> <tr> <th rowspan="2">X (mm) Y (mm)</th> <th rowspan="2">Zone</th> <th colspan="2">Acceptable number</th> <th rowspan="2">Class Of Defects</th> <th rowspan="2">AQL Level</th> </tr> <tr> <th>A</th> <th>B</th> </tr> </thead> <tbody> <tr> <td>* 0.04 ≥ W</td> <td></td> <td>*</td> <td>*</td> <td rowspan="4">Minor</td> <td rowspan="4">2.5</td> </tr> <tr> <td>3.0 ≥ L 0.06 ≥ W</td> <td></td> <td>4</td> <td>4</td> </tr> <tr> <td>2.0 ≥ L 0.08 ≥ W</td> <td></td> <td>2</td> <td>3</td> </tr> <tr> <td>— 0.1 < W</td> <td></td> <td>0</td> <td>1</td> </tr> </tbody> </table> <p>X : Length Y : Width * : Disregard</p> <p>Total defects should not exceed 4/module</p>	X (mm) Y (mm)	Zone	Acceptable number		Class Of Defects	AQL Level	A	B	* 0.04 ≥ W		*	*	Minor	2.5	3.0 ≥ L 0.06 ≥ W		4	4	2.0 ≥ L 0.08 ≥ W		2	3	— 0.1 < W		0	1
X (mm) Y (mm)	Zone	Acceptable number			Class Of Defects	AQL Level																						
		A	B																									
* 0.04 ≥ W		*	*	Minor	2.5																							
3.0 ≥ L 0.06 ≥ W		4	4																									
2.0 ≥ L 0.08 ≥ W		2	3																									
— 0.1 < W		0	1																									
3	Air Bubbles (between glass & polarizer)	<table border="1"> <thead> <tr> <th rowspan="2">Zone Dimension</th> <th colspan="2">Acceptable number</th> <th rowspan="2">Class of Defects</th> <th rowspan="2">AQL Level</th> </tr> <tr> <th>A</th> <th>B</th> </tr> </thead> <tbody> <tr> <td>D ≤ 0.15</td> <td>*</td> <td>*</td> <td rowspan="3">Minor</td> <td rowspan="3">2.5</td> </tr> <tr> <td>0.15 < D ≤ 0.25</td> <td>2</td> <td>*</td> </tr> <tr> <td>0.25 < D</td> <td>0</td> <td>1</td> </tr> </tbody> </table> <p>* : Disregard</p> <p>Total defects shall not excess 3/module.</p>	Zone Dimension	Acceptable number		Class of Defects	AQL Level	A	B	D ≤ 0.15	*	*	Minor	2.5	0.15 < D ≤ 0.25	2	*	0.25 < D	0	1								
Zone Dimension	Acceptable number			Class of Defects	AQL Level																							
	A	B																										
D ≤ 0.15	*	*	Minor	2.5																								
0.15 < D ≤ 0.25	2	*																										
0.25 < D	0	1																										

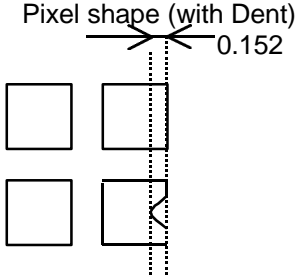
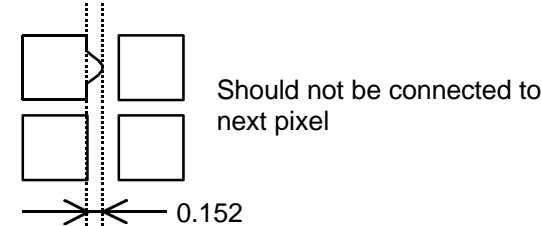
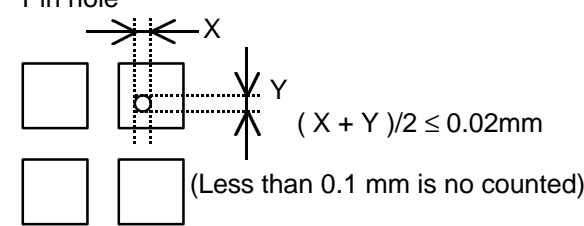
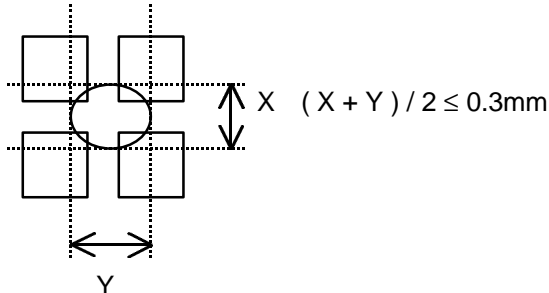
4	Uniformity of Pixel	<p>(1) Pixel shape (with Dent)</p>  <p>(2) Pixel shape (with Projection)</p>  <p>(3) Pin hole</p>  <p>(4) Deformation</p>  <p>Total acceptable number : 1/pixel, 5/cell</p>
---	---------------------	---

12. LOT NUMBERING SYSTEM

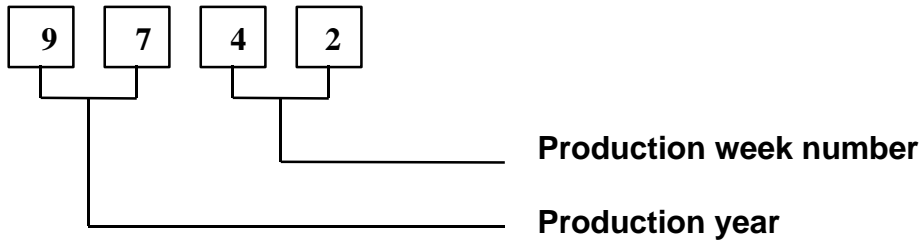

13. LCM NUMBERING SYSTEM

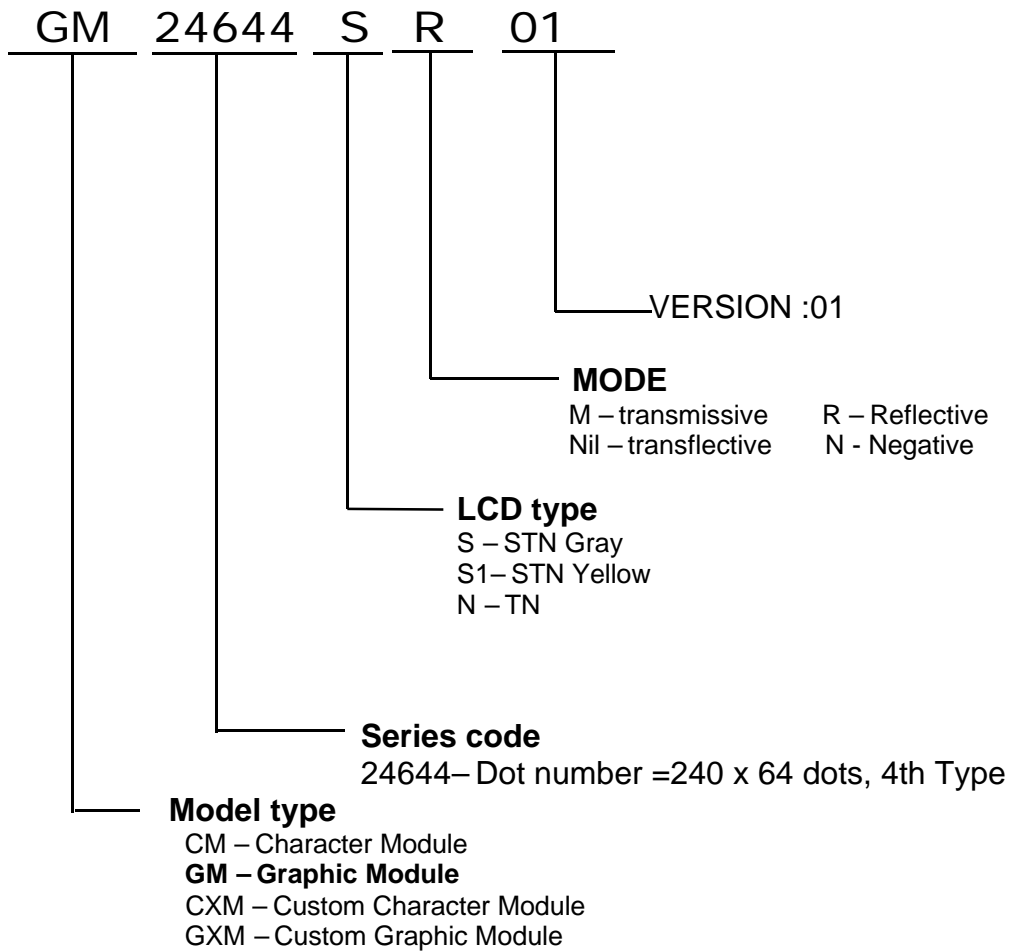

14. PRECAUTION FOR USING LCM

1. LIQUID CRYSTAL DISPLAY (LCD)

LCD is made up of glass, organic sealant, organic fluid, and polymer based polarizers. The following precautions should be taken when handling,

- (1). Keep the temperature within range of use and storage. Excessive temperature and humidity could cause polarization degradation, polarizer peel off or bubble.
- (2). Do not contact the exposed polarizers with anything harder than an HB pencil lead. To clean dust off the display surface, wipe gently with cotton, chamois or other soft material soaked in petroleum benzine.
- (3). Wipe off saliva or water drops immediately. Contact with water over a long period of time may cause polarizer deformation or color fading, while an active LCD with water condensation on its surface will cause corrosion of ITO electrodes.
- (4). Glass can be easily chipped or cracked from rough handling, especially at corners and edges.
- (5). Do not drive LCD with DC voltage.

2. Liquid Crystal Display Modules

2.1 Mechanical Considerations

LCM are assembled and adjusted with a high degree of precision. Avoid excessive shocks and do not make any alterations or modifications. The following should be noted.

- (1). Do not tamper in any way with the tabs on the metal frame.
- (2). Do not modify the PCB by drilling extra holes, changing its outline, moving its components or modifying its pattern.
- (3). Do not touch the elastomer connector, especially insert a backlight panel (for example, EL).
- (4). When mounting a LCM make sure that the PCB is not under any stress such as bending or twisting. Elastomer contacts are very delicate and missing pixels could result from slight dislocation of any of the elements.
- (5). Avoid pressing on the metal bezel, otherwise the elastomer connector could be deformed and lose contact, resulting in missing pixels.

2.2. Static Electricity

LCM contains CMOS LSI's and the same precaution for such devices should apply, namely

- (1). The operator should be grounded whenever he/she comes into contact with the module. Never touch any of the conductive parts such as the LSI pads, the copper leads on the PCB and the interface terminals with any parts of the human body.
- (2). The modules should be kept in antistatic bags or other containers resistant to static for storage.
- (3). Only properly grounded soldering irons should be used.
- (4). If an electric screwdriver is used, it should be well grounded and shielded from commutator sparks.

(5) The normal static prevention measures should be observed for work clothes and working benches; for the latter conductive (rubber) mat is recommended.

(6). Since dry air is inductive to static, a relative humidity of 50-60% is recommended.

2.3 Soldering

- (1). Solder only to the I/O terminals.
- (2). Use only soldering irons with proper grounding and no leakage.
- (3). Soldering temperature : $280^{\circ}\text{C} \pm 10^{\circ}\text{C}$
- (4). Soldering time: 3 to 4 sec.
- (5). Use eutectic solder with resin flux fill.
- (6). If flux is used, the LCD surface should be covered to avoid flux spatters. Flux residue should be removed afterwards.

2.4 Operation

- (1). The viewing angle can be adjusted by varying the LCD driving voltage V_0 .
- (2). Driving voltage should be kept within specified range; excess voltage shortens display life.
- (3). Response time increases with decrease in temperature.
- (4). Display may turn black or dark blue at temperatures above its operational range; this is (however not pressing on the viewing area) may cause the segments to appear "fractured".
- (5). Mechanical disturbance during operation (such as pressing on the viewing area) may cause the segments to appear "fractured".

2.5 Storage

If any fluid leaks out of a damaged glass cell, wash off any human part that comes into contact with soap and water. Never swallow the fluid. The toxicity is extremely low but caution should be exercised at all the time.

2.6 Limited Warranty

Unless otherwise agreed between DATA IMAGE and customer, DATA IMAGE will replace or repair any of its LCD and LCM which is found to be defective electrically and visually when inspected in accordance with DATA IMAGE acceptance standards, for a period on one year from date of shipment. Confirmation of such date shall be based on freight documents. The warranty liability of DATA IMAGE is limited to repair and/or replacement on the terms set forth above. DATA IMAGE will not be responsible for any subsequent or consequential events.

15 OUTLINE DRAWING

UNITS MM

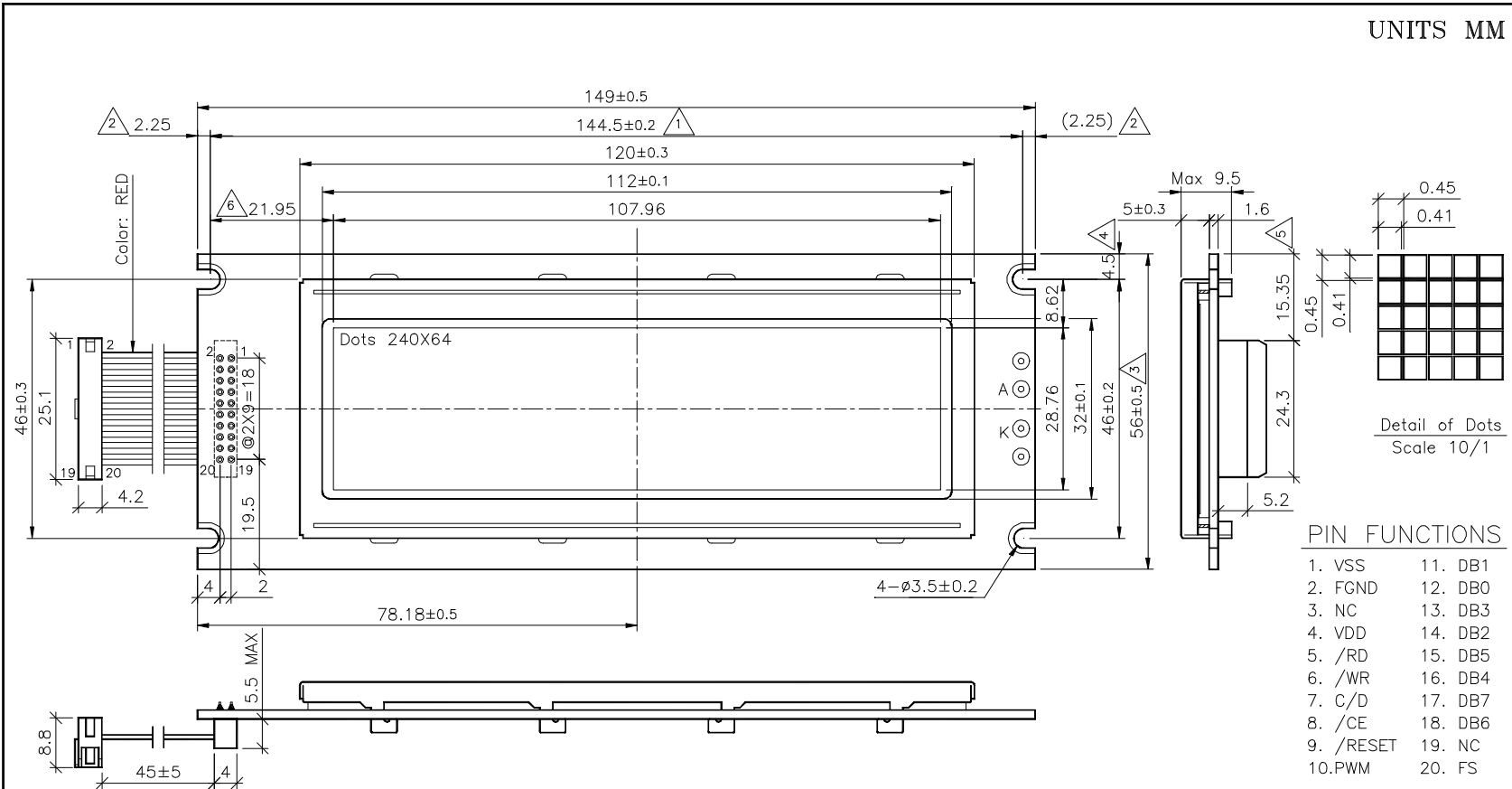

NOTE: ALL WITHOUT TOLERANCE FOR \pm 0.3mm

REV	DESCRIPTION	DATE	APPROVED
6	CHANGE PCB LOCATE HOLE DIMENSION BY COSTOMER, FROM 22.2 TO 21.95	09/01/99	
5	CHANGE CONNECTOR LOCATE DIMENSION BY COSTOMER, FROM 16.35 TO 15.35	09/01/99	
4	CHANGE PCB LOCATE HOLE DIMENSION BY COSTOMER, FROM 5.5 TO 4.5	09/01/99	
3	CHANGE PCB OUTLINE DIMENSION BY COSTOMER, FROM 57 \pm 0.5 TO 56 \pm 0.5	09/01/99	
2	CHANGE PCB LOCATE HOLE DIMENSION BY COSTOMER, FROM 2 TO 2.25	09/01/99	
1	CHANGE PCB LOCATE HOLE DIMENSION BY COSTOMER, FROM 145 \pm 0.3 TO 144.5 \pm 0.2	09/01/99	
AUTH		DATE	APPROVED
REVISIONS			

ISSUE DATE:	03/18/99	DATA IMAGE Corporation	
DRAWN:		TITLE: LCM OUTLINE DIMENSION	
CHECK:		DWG. NO. Q990308	
APPROVE:		PART. NO. GM24644	REV. D
SCALE 1 / 1		SHEET 1 OF 1	